

OPERATION AND MAINTENANCE

MODELS 708 & 835 SCBA FILL ADAPTERS

The model 708 fill adapter is designed to fill only 4500 PSI SCBA cylinders. If accidentally attached to the more common 2215 PSI cylinder a unique internal vent mechanism opens and prevents the cylinder from filling. Thus the danger of an inexperienced operator attaching a low pressure cylinder to a higher pressure line is eliminated.

The model 835 fill adapter is a straight adapter without the relief feature. It can be used to fill either the 4500 or 2215 PSI cylinders thus is normally used only on the lower pressure fill line.

In facilities where both high and lower pressure fill lines are provided the 708 and 835 adapters can provide a matched set. The 708 is silver anodized and the 835 is gold anodized and slightly shorter. Both adapters use a unique O ring sealed tip. Light finger tightening assures a good seal.

SPECIFICATIONS

- Maximum rated press. 6000 PSI
 - Materials seals Viton
 - body aluminum
 - Inlet 1/4" MNPT
 - Size 1.5" dia.
- 3.0" long
- Fits standard CGA valves
 - Model 708 seals on 4500 PSI cylinders but vents on lower pressure cylinders
 - Model 835 seals on either type cylinder

INSTALLATION

Use a suitable pipe thread sealant. Do not over torque. Use average torque using a 6 or 8 inch wrench. Use ample Teflon tape - 3 or 4 turns not 1 or 2. Tightened by removing retainer clip item 5 and sliding the nut item 2 back to expose the wrench hex on the stem. Then slide the nut forward and, if desired, install the spring clip to keep the nut in the forward position. It is recommended a bleed or vent valve such as our model 712 valve be used to vent line pressure after filling a cylinder.

It is best to use the adapter at the end of a flexible high pressure hose. This eliminates unnecessary strain on the adapter and cylinder valve associated with rigid pipe connections. See CAUTION below regarding hose length.

The fitting is NOT shipped oxygen clean and should NOT be used for oxygen service as provided. Consult the factory for details on oxygen service.

MAINTENANCE & USE

Should the valve become leaky replace the O ring seal item 6. Take care not to scratch the metal stem when removing the old seal. Light finger tightening is all that's required when attaching the adapter to a tank. Over-tightening only serves to shorten seal and thread life.

CAUTION

Although these adapters will last many years under normal usage, as with any adapter, extensive usage under harsh conditions may cause premature wear on the threads of the nut item 2. (see drawing opposite side) This wear can be accelerated if the mating tank valve threads are damaged or excessive force is used in attaching the adapter to the tank. **The adapter should be inspected on a weekly basis for excessive looseness and thread wear.** If the thread appears worn the nut (item 2) should be replaced. **Excessively worn threads could result in failure under pressure and injury due to hose whip.** To reduce hose whip in the event of an adapter or tank valve failure or if pressure is accidentally applied to a unconnected hose, be sure the hose is tied down near the adapter. Avoid using long, unrestrained hoses. **Keep hoses as short as possible. Long hoses will whip dangerously in the event they become loose while under pressure.**

To prevent hose whip the adapter comes with an orifice (item 10) installed in the inlet end of the adapter. This orifice is designed for normal forward flow from the 1/4" MNPT end to the cylinder end. High pressure gas going in the reverse direction, outlet to inlet, could eject the orifice from the adapter. Under normal conditions there would be a hose or other fitting on the end of the adapter; however, if the adapter is inlet is not connected to anything and the adapter is subjected to reverse flow, then the orifice could be ejected and cause injury.

To avoid accelerated thread wear:

- a. Inspect tank valve threads for damage or dents and repair or replace damaged threads.
- b. When attaching the fitting to a tank, light finger pressure is all that is required. Never use wrenches or tools. If hard to turn, replace the damaged tank valve or fitting as required.
- c. Hold the fill hose in alignment with the tank so a minimum of force is required when attaching the adapter to the tank.

PARTS LIST MODEL 708

ITEM	QTY	PART NO.	DISC.
1	1	710	stem (3.1" lg.)
2	1	709	nut
3	1	711	collar
4	1	708-4	retainer-5103-37
5	1	708-5	retainer-5103-56
6	1	708-6	seal 2-010 -90V
7	1	708-7	seal 2-011 -90V
8	1	708-8	seal 2-013 -90V
9	1	708-9	repair kit - includes 4,5,6,7,8
10	1	1298	orifice

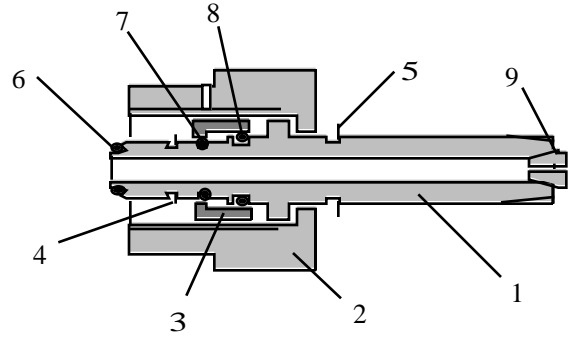

MODEL 708

PARTS LIST MODEL 835

ITEM	QTY	PART NO.	DISC.
1	1	834	stem (2.5" lg.)
2	1	709-1	nut
5	1	835-5	retainer 5103-56
6	1	835-6	seal 2-010 -90V
7	1	1298	orifice

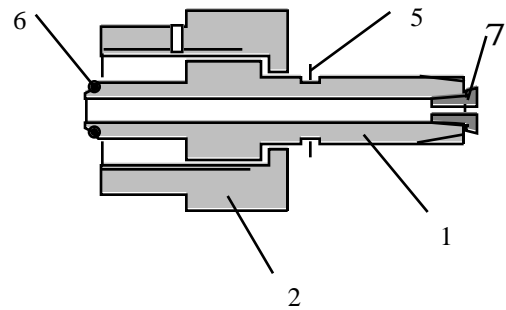

MODEL 835

NOTES;

1. Technical bulletin - 730
2. Standard flow limiting orifice is .040"